

Stufa a pellet modello Pellet stoves model:

Fra parentesi valori con ventilazione ambiente spenta
In brackets values with ambience fan off

CARATTERISTICHE	FEATURES	U.M	VALORE VALUE
Altezza	Height	mm	1125
Larghezza	Width	mm	610
Profondità	Depth	mm	630
Potenza termochimica max	Heat Input max	kW	25,0 (26,0)
Potenza termochimica min	Heat Input min	kW	8,2 (8,2)
Potenza nominale max	Nominal heat max	kW	24,0 (24,1)
Potenza nominale min	Nominal heat min	kW	7,6 (7,7)
Rendimento max	Efficiency max	%	94,1 (94,4)
Rendimento min	Efficiency min	%	93,5 (94,5)
Potenza all'acqua max	Water heat output max	kW	17,3 (18,5)
Potenza all'acqua min	Water heat output min	kW	6,0 (6,5)
Potenza all'aria max	Space heat output max	kW	6,7 (5,6)
Potenza all'aria min	Space heat output min	kW	1,6 (1,2)
Capacità serbatoio	Tank capacity	Kg	35,0
Consumo orario pellet max	Hourly pellet consumption max	Kg	5,0
Consumo orario pellet min	Hourly pellet consumption min	Kg	1,6
Autonomia di lavoro max	Working autonomy max	h	22
Autonomia di lavoro min	Working autonomy min	h	7
Superficie riscaldabile	Heatable surface	m ²	160,0
Ø uscita scarico fumi pellet	Ø pellet smoke outlet	mm	80,0
Tiraggio max	Draft max	mbar	12,0
Tiraggio min	Draft min	mbar	11,0
Ø entrata aria comburente pellet	Ø pellet primary air inlet	mm	50,0
Prevalenza circolatore	Water circulator prevalence	m	5,0
Pressione d'utilizzo a freddo	Pressure on cold working mode	bar	0,8 / 1,2
Dimensione vaso d'espansione	Expansion vase size	l	6,0
Produzione acqua sanitaria (optional)	Hot drinking water production (option)	lt/min	10,0
Tensione d'alimentazione	Working voltage supply	V	220V/50Hz
Assorbimento elettrico in fase lavoro	Electric absorbment in working mode	W	170,0
Peso	Weight	Kg	217

Prove eseguite usando come combustibile pellet di legno con potere calorifico pari a 4.9 kWh/kg.
Tests done using wood pellet (as full) with heating power of 4.9 kWh/kg.

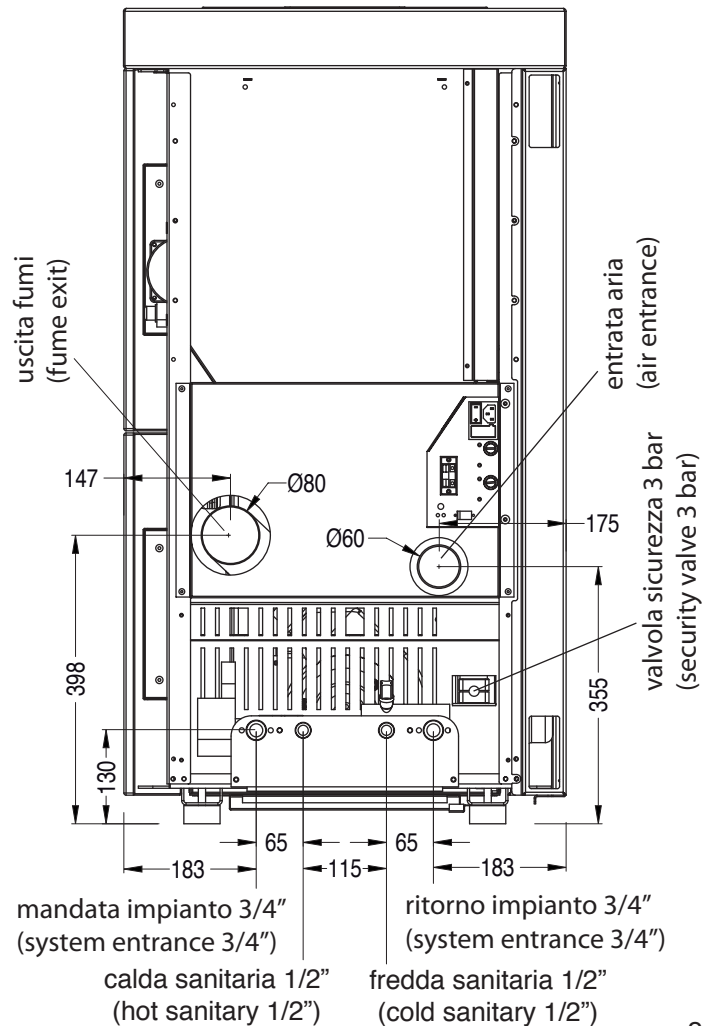
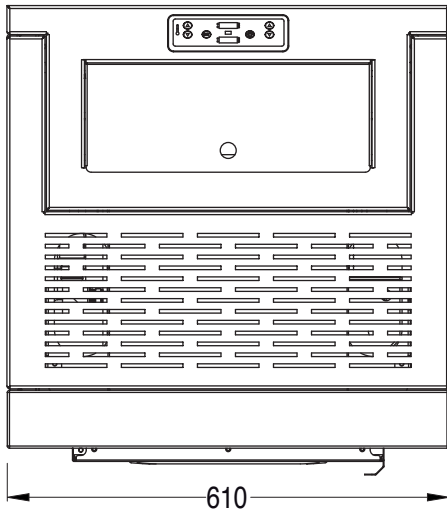
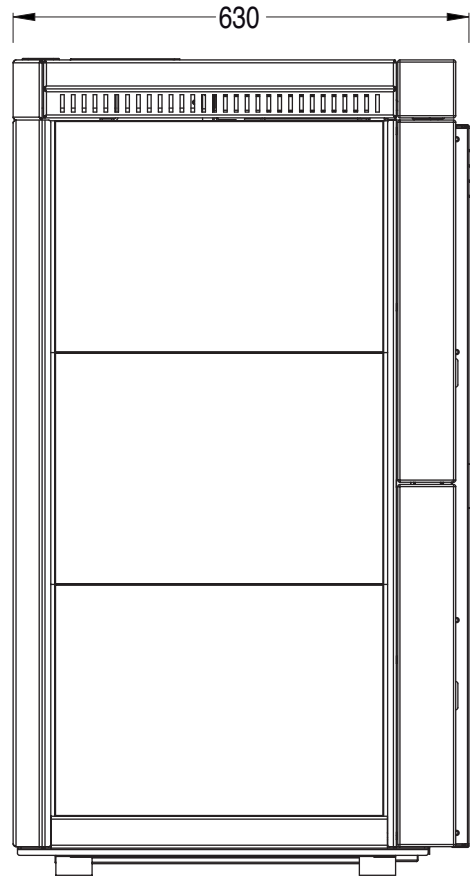
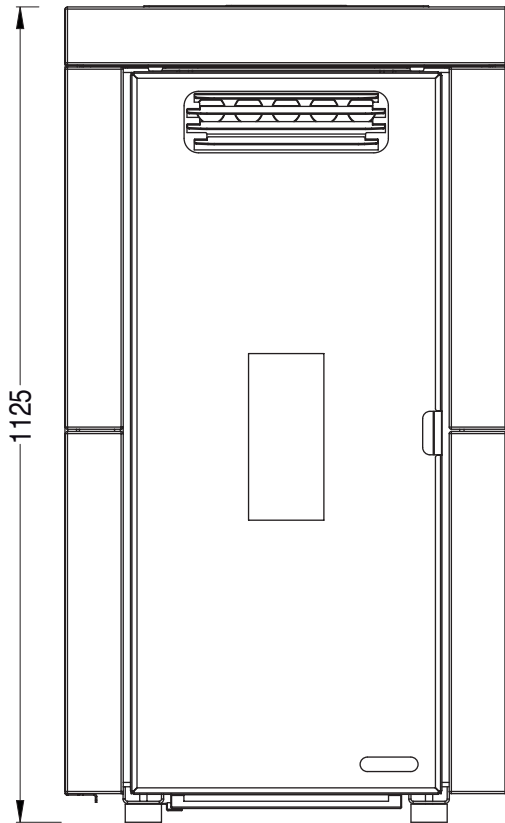

Stufa a pellet modello
Pellet stoves model:
BLEND 24